

FilterBox 12A+

Versatile Filter for Production Fume Control

Improved Working Air Quality

FilterBox 12A+ stationary is an essential unit designed to control weld fumes and non-combustible dusts in production environments. Suitable for heavy-duty welding fume and dust applications, providing the flexibility of using a suitable extraction arm from selection or custom connections required as per application.

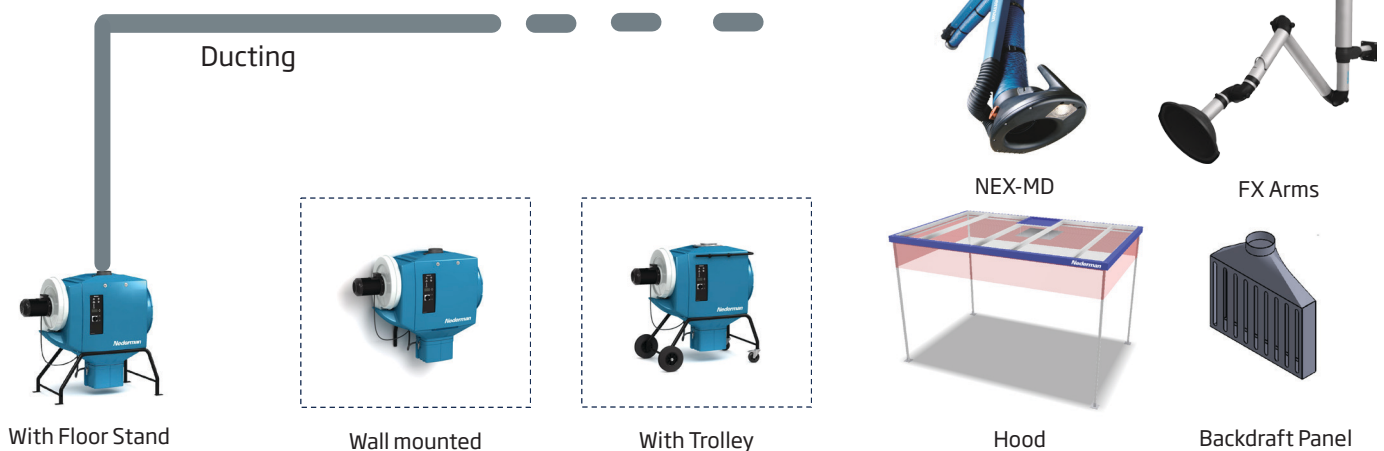

General Features

The unit offers an advanced build-in filter control system and filter medias ideal for use in production welding such as MIG welding, TIG welding and other GMAW welding methods.

- Automatically operated filter cleaning with compressed air for long filter life.
- LCD panel with operating status and menu system for parameter setup and settings.
- Automatic damper preventing dust from leaking out while cleaning.
- Airflow and filter life indicator visually/audibly notify users when maintenance required.
- Dust free filter replacement and emptying of dust bin.
- High-efficient MERV 15 rated Nanofiber primary filter media or optional ePTFE filter media.
- Auto on/off interlock ready.

Configurable solution for various needs

The solution offers various fan arrangements tailored to specific application requirements. The standard base unit includes a floor stand without arms, providing versatility for different setups. Additionally, the unit can be converted into a mobile configuration using a trolley or mounted on the wall for space optimization.

General Specifications

Model	Max Airflow	Filter Area	FanPower	Input Power
	CFM (m ³ /h)	ft ² (m ²)	Hp (kW)	
FilterBox 12A+	750 (1275)	183 (17)	1.5 (1.1)	120V/ 1PH / 50Hz
	750 (1275)		1.5 (1.1)	230V/ 1PH / 60Hz
	800 (1360)		2 (1.5)	208V/ 3PH / 60Hz
	800 (1360)		2 (1.5)	460V/ 3PH / 60Hz
	800 (1360)		2 (1.5)	575V/ 3PH / 60Hz

Accessories

Options	Description
Floor Stand to Trolley	Converts available FilterBox floor stands to trolley
Wall Mount	Required to mount FilterBox easily to wall
HEPA Filter	H14 rated HEPA after filter option for high-toxicity fume including hexavalent chrome
Sensor clamp	Automates fume extraction with current sensing clamp. Includes timer to capture residual fume when welding is finished

General Dimensions

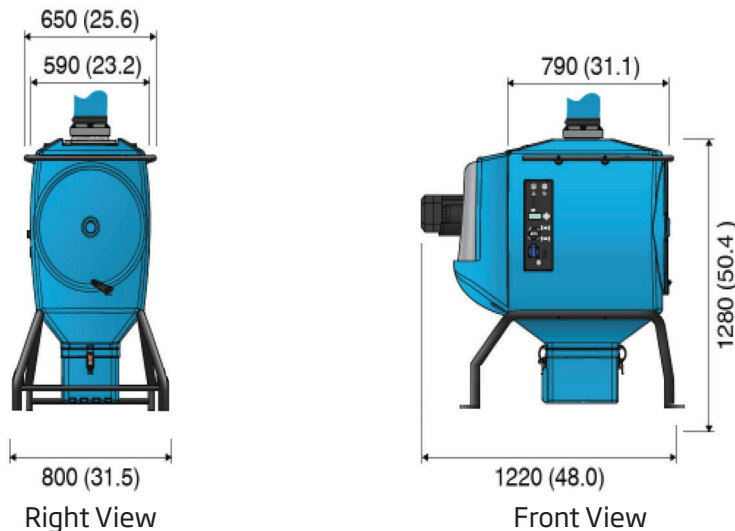

mm (inches)